

24" SQUARE CONCRETE PAD OR AC PAVEMENT OUTSIDE OF PAVED AREAS. SLOPE AWAY FROM CLEANOUT.

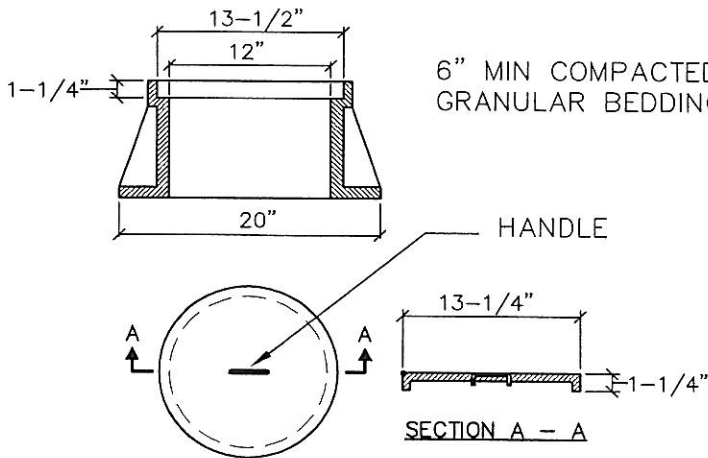
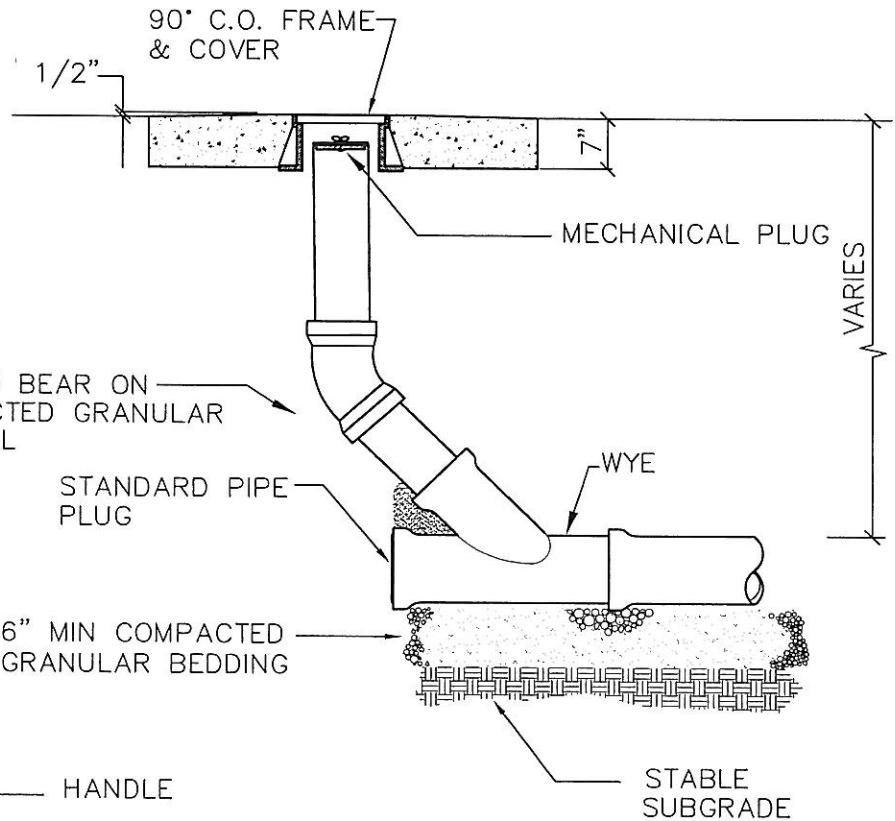
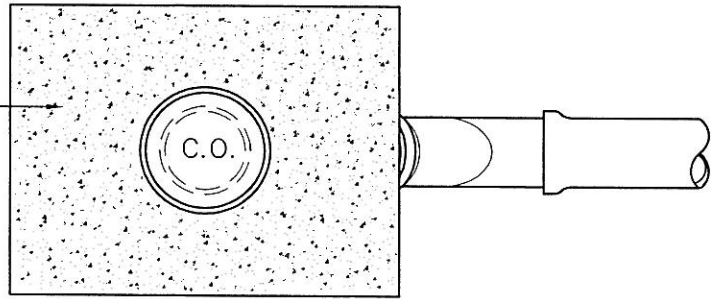

CLEANOUT FRAME & COVER

NOTES:

1. USE INLAND FOUNDRY MODEL 240 FRAME & COVER IN ALL AREAS.
2. COVER AND FRAME SHALL BE GRAY CAST IRON ASTM A-48, CLASS 30.
3. COVER AND FRAME TO BE MACHINED TO A TRUE BEARING ALL AROUND.

LAST REVISION DATE: DEC 2004	COPYRIGHT 1996 WESTECH ENGINEERING, INC
MAINLINE CLEANOUT (NTS)	
JUNCTION CITY, OR	DETAIL NO. 411